

## Datasheet - PLCC Plugs

**\*\*\*\*Please note that the insulator was historically manufactured from Questa. This material is now obsolete and will be phased out once stock is depleted\*\*\*\***

**The new insulator will be manufactured from Stanyl which is a higher grade plastic, suitable for RoHS compliant reflow temperatures (see last page for details).**

**The colour of the insulator will change from black (Questa) to natural (Stanyl)**

**Please contact the nearest [Winslow Adaptics sales office](#) for more information.**

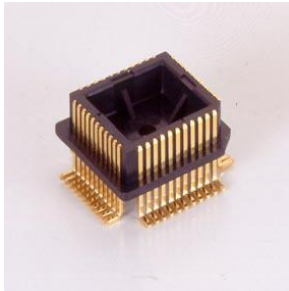

SMT (Large Outline)



SMT (Small Outline)

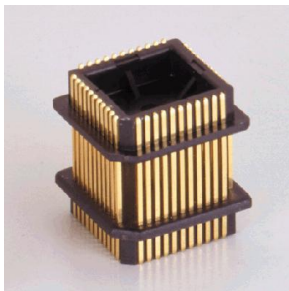

Double Ended

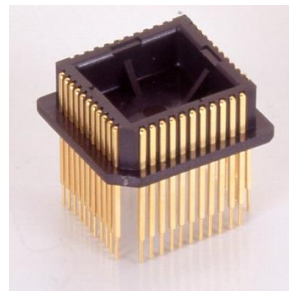

Thru Board

### Solutions to Component Leadtime and Obsolescence



Also available from Winslow Adaptics are cost effective, time saving solutions to test, obsolescence, supply problems and upgrades. OEMs can upgrade equipment with custom Adaptics utilising additional logic, often saving considerable cost and time on re-design. If lead-time becomes an issue contact us for a suitable package converter. We specialise in conversion of all package lead-frames. For further information please contact your nearest sales office

## Large Footprint Surface-Mount Plugs

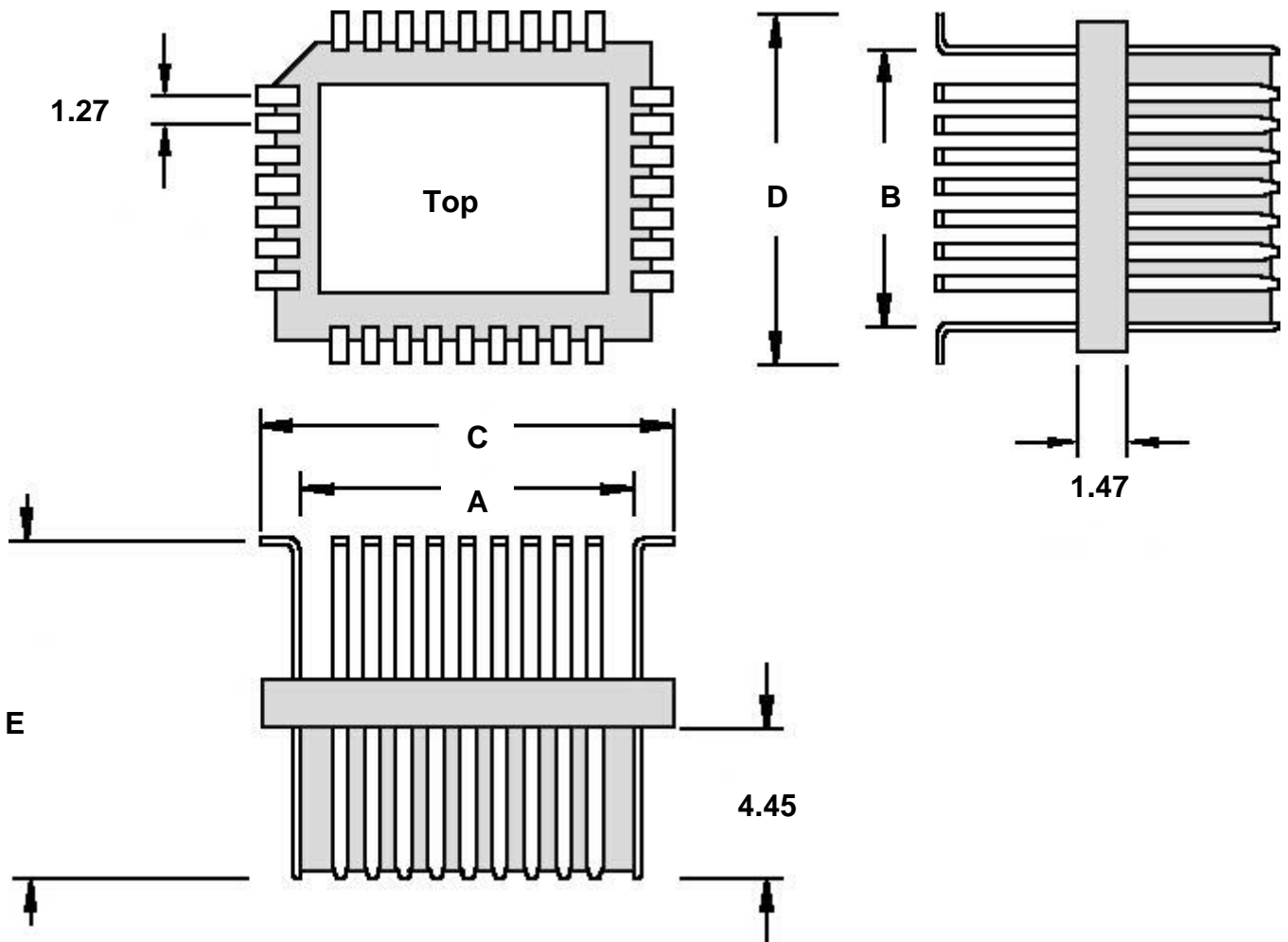

Number of pins shown is for illustration only. Plugs with longer pins may use two mouldings.

### Adapter Dimension Table

RS Part Number	Part Number	PLCC Pins	A	C	D	B
4350602	W9322	20	8.7	15	15	8.7
4350668	W9323	28	11.15	17.4	17.4	11.15
4350618	W9324	32	13.6	19.9	17.4	11.02
4350624	W9325	44	16.4	22.5	22.5	16.4
4350630	W9326	52	18.9	25.1	25.1	18.9
4350646	W9327	68	23.9	30.1	30.1	23.9
4350652	W9328	84	28.9	35.2	35.2	28.9

### Pin Variations

Suffix denoting Pin Length	E
-ZC138	10.2
-ZC158	9.3
-ZC160	7.2
<b>NO SUFFIX</b>	<b>15.5</b>

Example: For W9322-ZC158, E is 9.3mm

All dimensions in mm, and subject to change without notice.

If pin variations not available through RS Components; please contact your nearest Winslow Sales office direct.



# WINSLOW ADAPTICS

Surface mount PLCC Plug (Large Outline) recommended pad layouts

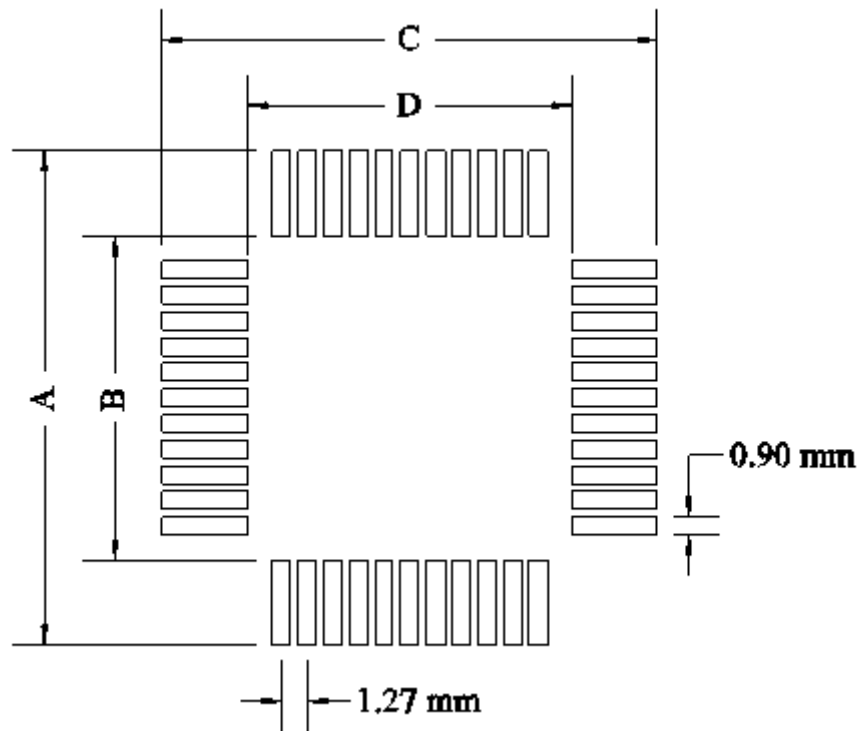

Part Number	A	B	C	D
W9322	16.3	7.2	16.3	7.2
W9323	18.8	9.7	18.8	9.7
W9324	18.8	9.7	21.3	12.2
W9325	23.9	14.8	23.9	14.8
W9326	26.4	17.3	26.4	17.3
W9327	31.5	22.4	31.5	22.4
W9328	36.6	27.5	36.6	27.5

**All dimensions in millimeters unless otherwise specified  
All information may be subject to change without prior notice**

### Small Footprint Surface-Mount Plugs

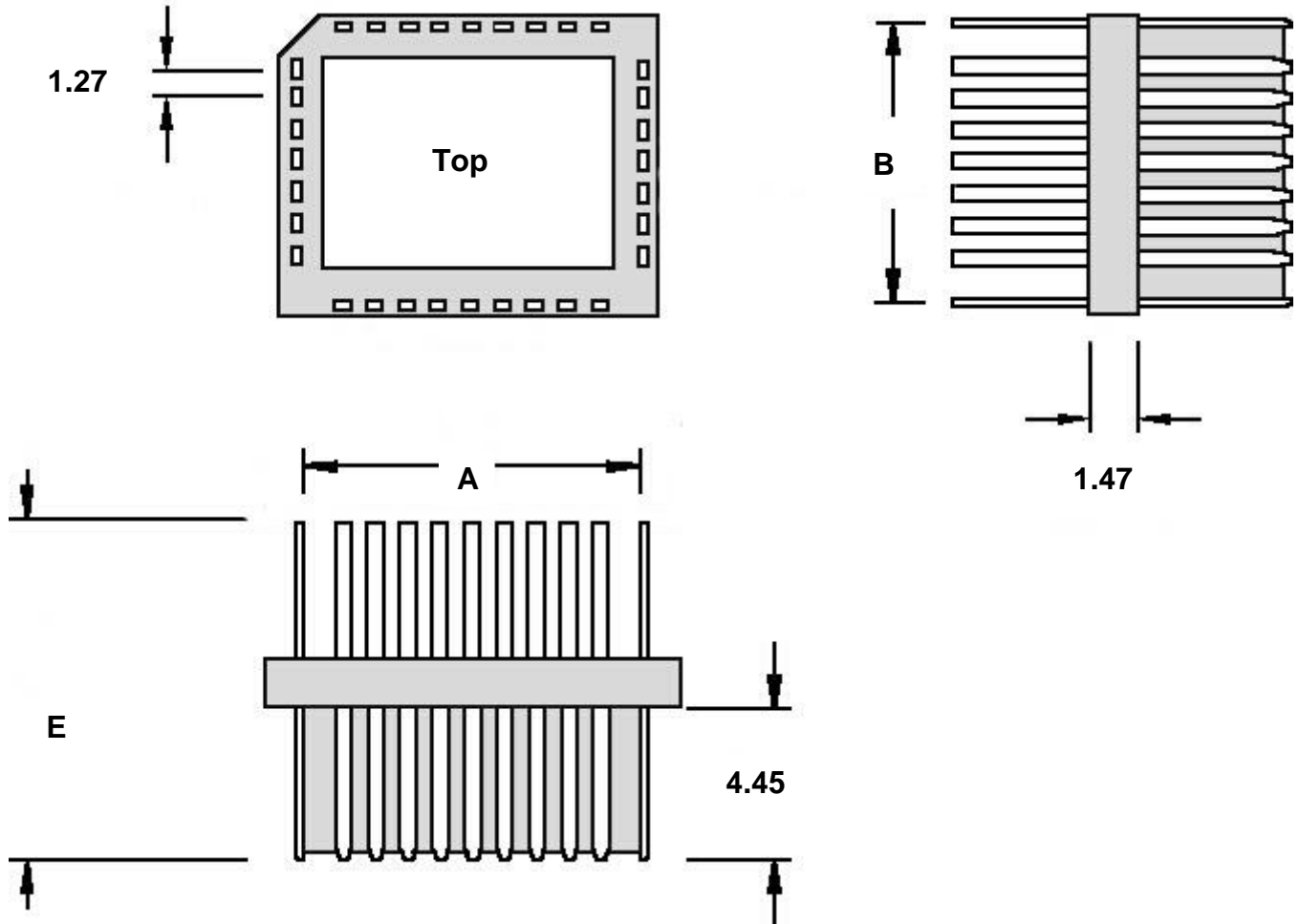

Number of pins shown is for illustration only. Plugs with longer pins may use two mouldings.

#### Adapter Dimension Table

RS Part Number	Part Number	PLCC Pins	A	B
	W9379	20	8.7	8.7
	W9380	28	11.15	11.15
	W9381	32	13.6	11.02
	W9382	44	16.4	16.4
	W9383	52	18.9	18.9
	W9384	68	23.9	23.9
	W9385	84	28.9	28.9

#### Pin Variations

Suffix denoting Pin Length	E
-ZC174	8.3
-ZC170	21.6
<b>NO SUFFIX</b>	<b>15.8</b>

Example: For W9379-ZC174, E is 8.3mm

All dimensions in mm, and subject to change without notice.

If pin variations not available through RS Components; please contact your nearest Winslow Sales office direct.

## Butt-Jointing Surface-Mount Plugs

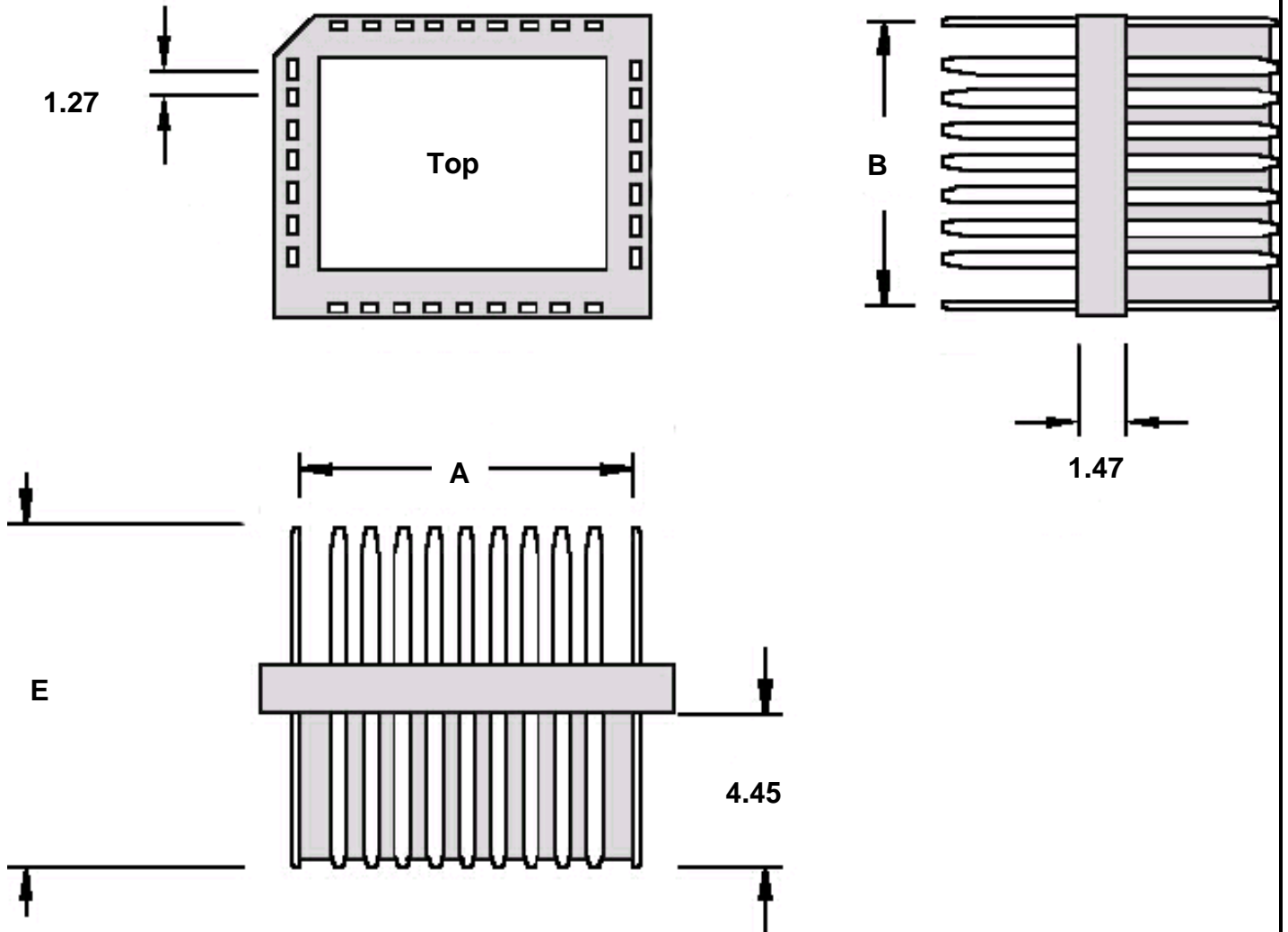

Number of pins shown is for illustration only. Plugs with longer pins may use two mouldings.

### Adapter Dimension Table

RS Part Number	Part Number	PLCC Pins	A	B
	W9190	20	8.7	8.7
	W9191	28	11.15	11.15
	W9192	32	13.6	11.02
	W9193	44	16.4	16.4
	W9194	52	18.9	18.9
	W9195	68	23.9	23.9
	W9196	84	28.9	28.9

### Pin Variations

Suffix denoting Pin Length	E
-ZC156	10.8
-ZC155	15.2
-ZC163	21.6
-ZC157	29.2
<b>NO SUFFIX</b>	<b>16.5</b>

Example: For W9190-ZC155, E is 15.2mm

All dimensions in mm, and subject to change without notice.

If pin variations not available through RS Components; please contact your nearest Winslow Sales office direct.

### Double-Ended Plugs

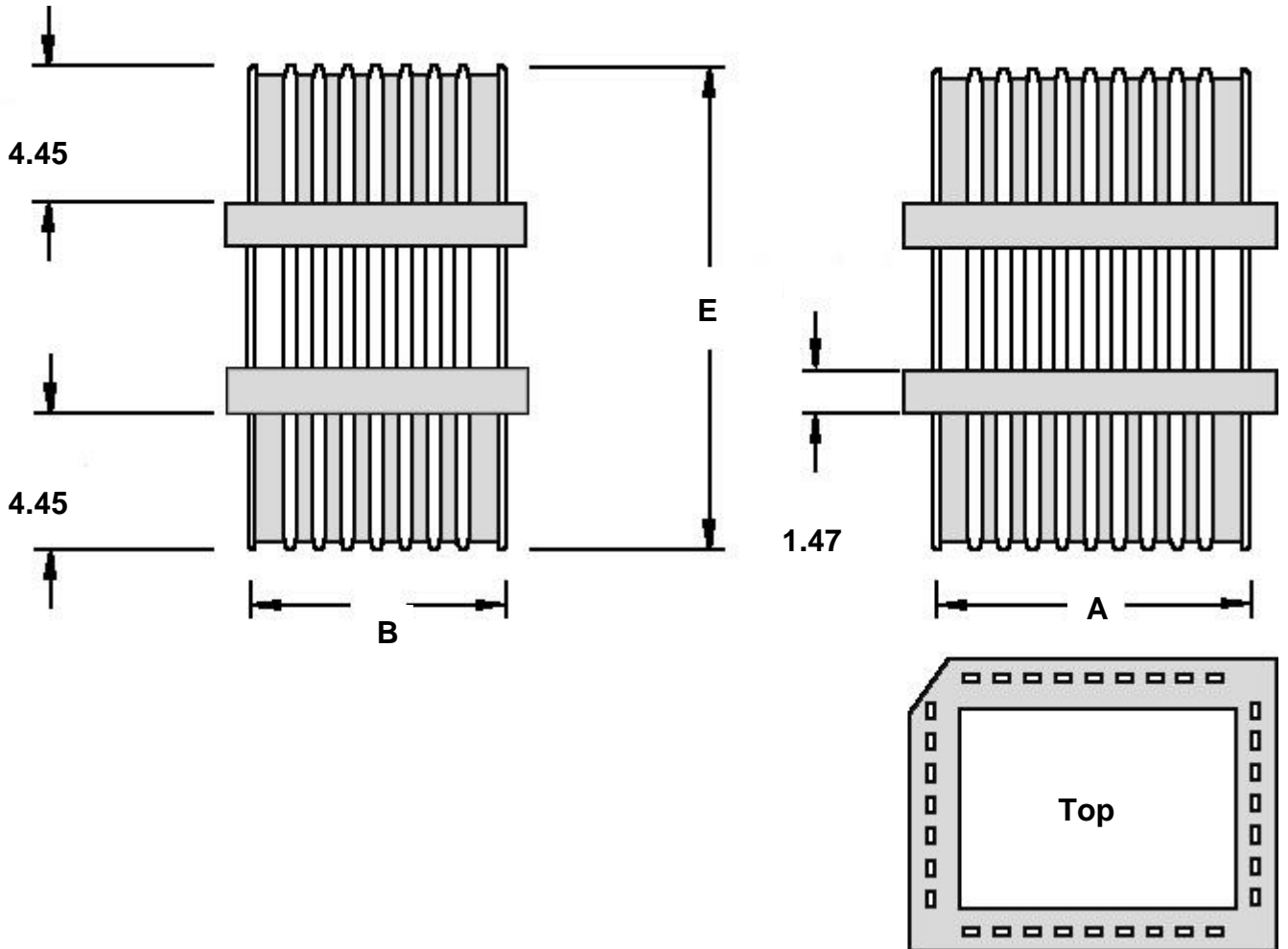

Number of pins shown is for illustration only. Plugs with longer pins may use two mouldings.

#### Dimension Table

RS Part Number	Part Number	PLCC Pins	A	B
	W9314	20	8.7	8.7
	W9315	28	11.15	11.15
	W9316	32	13.6	11.02
	W9317	44	16.4	16.4
	W9318	52	18.9	18.9
	W9319	68	23.9	23.9
	W9320	84	28.9	28.9

#### Pin Variations

Suffix denoting Pin Length.	E
-ZC154	16.5
-ZC155	15.2
-ZC156	10.8
-ZC157	29.2
-ZC162	21
<b>NO SUFFIX</b>	<b>21.6</b>

Example: For W9314-ZC162, E has a length of 21mm

All dimensions in mm, and subject to change without notice.

If pin variations not available through RS Components; please contact your nearest Winslow Sales office direct.

## Through-Board Plug

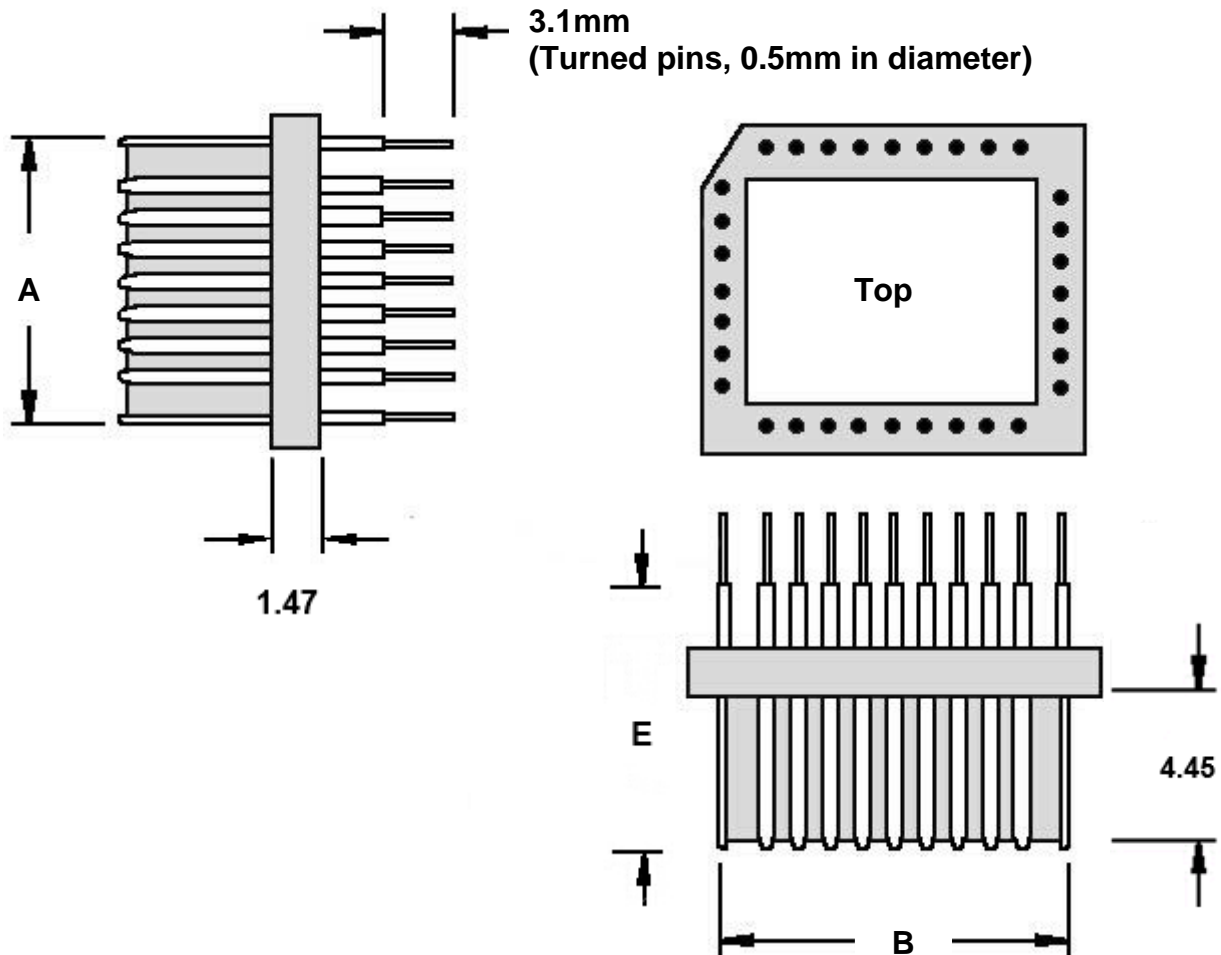

Number of pins shown is for illustration only. Plugs with longer pins may use two mouldings.

### Dimension Table

RS Part Number	Part Number	PLCC Pins	A	B
2446868	W9300	20	8.7	8.7
	W9301	28	11.15	11.15
2446880	W9302	32	13.6	11.02
2446896	W9303	44	16.4	16.4
2446903	W9304	52	18.9	18.9
2446919	W9305	68	24.5	24.5
2446925	W9306	84	29.5	29.5

### Pin Variations

Suffix denoting Pin Length.	E
- ZC168	6.8
- ZC185	8.3
- ZC187	9.6
- ZC189	15.5
<b>NO SUFFIX</b>	<b>11.7</b>

Example: For W9300-ZC168, E has a length of 6.8mm

All dimensions in mm, and subject to change without notice.

If pin variations not available through RS Components; please contact your nearest Winslow Sales office direct.



### Stanyl material properties:

Heat deflection temp:	290°C
Continuous use temp:	163°C @ 5000 hrs
Relative temp index:	140°C
Minimum operating temp:	-40°C
Flammability rating:	UL94V-0

Pin material:	Half hard brass
Plating material:	Au flash

Moisture absorption >0.5% baking required of 100 hours @ 80°C or 24 hours @ 105°C

These connectors are typically mounted by hand and wave soldering processes. However these connectors can also be mounted by reflow.

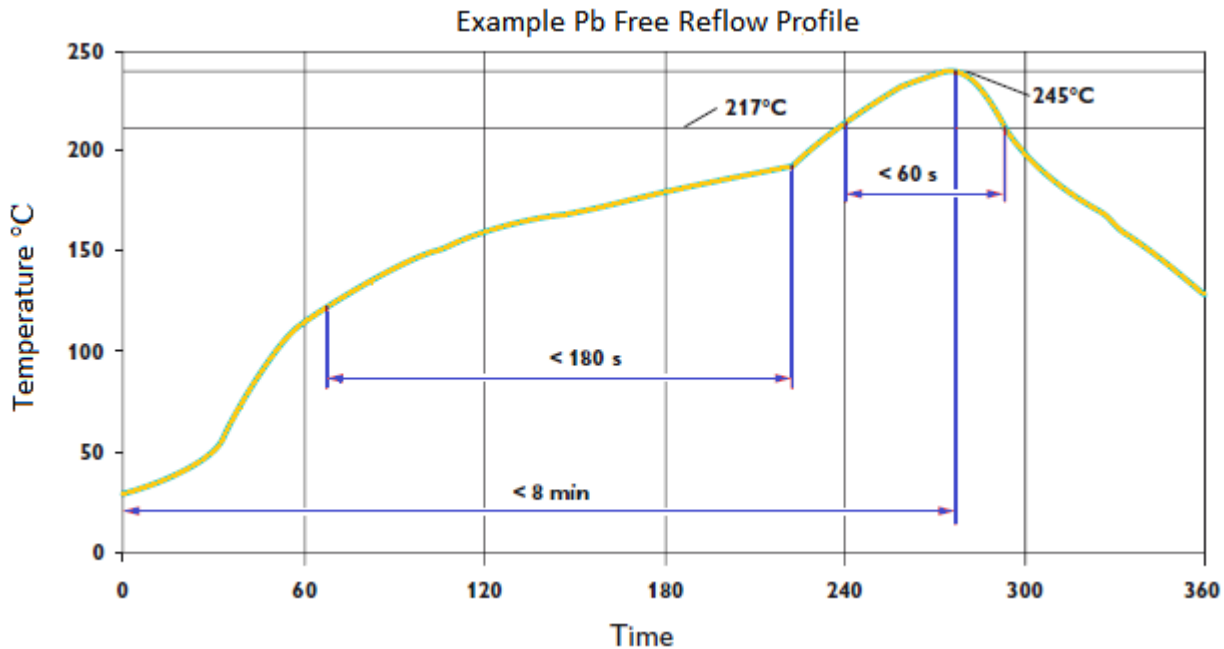

Product is RoHS and REACH compliant