

DRG. No.

A05-1006

FOR EXPLANATION OF DIMENSIONING, ETC. SEE B.S.308
 REMOVE ALL BURRS & SHARP EDGES.
 A RADIUS OR CHAMFER .02 (MAX.) IS PERMITTED IN CORNERS
 OF BLIND HOLES, RECESSES & STEPS.

THIRD ANGLE PROJECTION

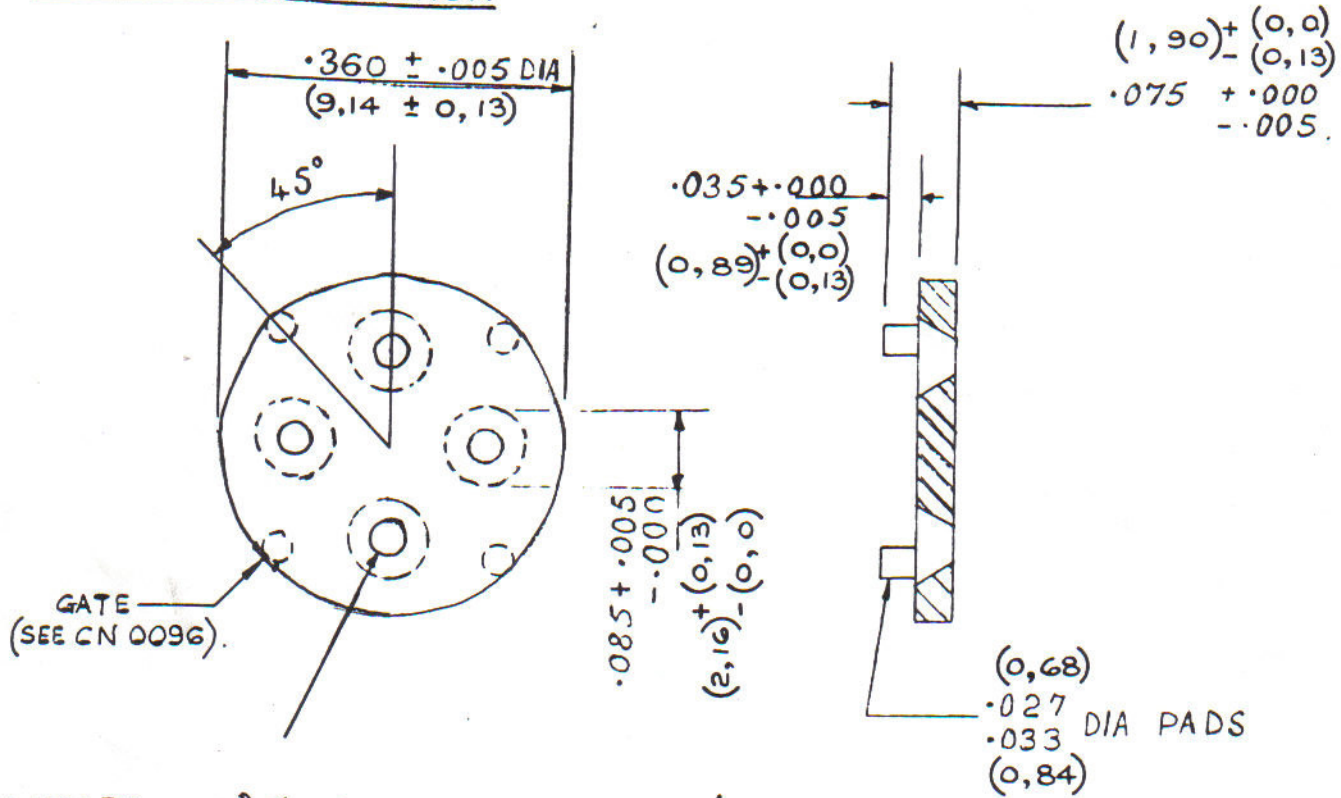

4 HOLES $.031$ (0.787) EQUI-SPACED ON
 $.200 \pm .005$ PC D

Part No	Rev No	Material
T05-006P	T05-1006P	Al407.

DATE	CHANGES		TOLERANCE	DRAWN
29-7-70	A	EQUIV. METRIC DIMS. ADDED.	$(0, 25)$ ± 0.010 u.s.	<i>E.P.</i>
1.3.78	B	Drawn Part No. added (21)	MATERIAL	TRACED
4.1.79	C	CN N° 0096.		CHECKED
				DATE 29 MAY 1966
TITLE			SCALE: 5:1	DRG. No.
MOUNTING PAD TRANSISTOR			DIMS. INCHES (mm)	A05-1006.

JERMYN INDUSTRIES VESTRY ESTATE, OTFORD, NR. SEVENOAKS, KENT.